

Laboratory Manual

For

**TRANSDUCER LAB.**  
**(IE-212)**

Prepared By

**Dr. Surita Maini**

Professor



Electrical and Instrumentation Engineering Department  
Sant Longowal Institute of Engineering & Technology  
Longowal, Sangrur, Punjab, India  
[www.sliet.ac.in](http://www.sliet.ac.in)

## **DOs and DON'Ts in Transducer lab.**

### **Dos**

1. Come prepared and on time for laboratory experiments.
2. Read all the instructions of the experiment carefully.
3. Select the measuring instruments for the designated range of the equipment's.
4. Always wear tight dresses and rubber shoes in the laboratory.
5. Make all the connections neat and tight.
6. Always increase the voltage or current gradually.
7. Use additional safety precautions for particular experiment, if any.

### **DON'Ts**

1. Never touch any live terminal by bare hands.
2. Never turn on the main switches of any experiment without getting checked the circuit by laboratory instructor.
3. Never turn on any circuit at full supply voltage, even if the reading is desired at rated voltage.

## **COURSE OUTCOMES:**

After successful completion of course, the students should be able to

**CO1:** Introduce different types of transducers.

**CO2:** Learn the construction and the working principle of Resistive transducer, Inductive transducer, Piezoelectric transducer, Capacitive transducer.

**CO3:** Study classification and construction of different Digital Encoding transducers.

**CO4:** Know different types of Photo emissive, Photovoltaic and Photoconductive cells.

**CO5:** Describe the Load Cell, Strain Gauge and Inductive Torque Meter.

To understand the practicability of sensors and transducers, the list of experiments is given below to be performed in the laboratory.

<b>S. No.</b>	<b>Name of Experiment</b>	<b>Page No.</b>	<b>Remarks</b>
1	To study the characteristics of LVDT	4	
2	To study the characteristics of Variable Capacitor.	6	
3	To study the characteristics of Light Dependent Resistor	9	
4	To study the characteristics of Strain Gauge.	11	
5	To study the characteristics of Crompton Potentiometer.	13	
6	To study the characteristics of Resistance Temperature Detector	16	
7	To study the characteristics of Thermistor.	18	
8	To study the characteristics of Thermocouple.	20	

## EXPERIMENT -1

**AIM:** To study characteristics of inductive transducer LVDT.

**APPARATUS REQUIRED:** - LVDT Kit

**THEORY:** - LVDT is most widely used in the inductive transducer, which Convert the linear motion into electrical signals. The transformer consists of secondary winding having equal number of turns and is identically placed on the either side of primary winding .The secondary are connected in the opposition. The primary winding is connected to an alternating current source. The moveable soft iron core is placed inside the former. The displacement, which is to be measured, is applied to the core. The frequency of AC supply to primary winding may be between 50 Hz to 20 KHz. Since the primary winding is excited by AC source it produces an alternating magnetic flux, which in turn induces alternating flux in the two secondary winding. The output voltage of secondary S1 is  $E_{s1}$  and that of S2 is  $E_{s2}$ . As the two secondary are connected in the series opposition the net output voltage is the difference of the two voltages produced in the two secondary windings as shown in figure 1.1

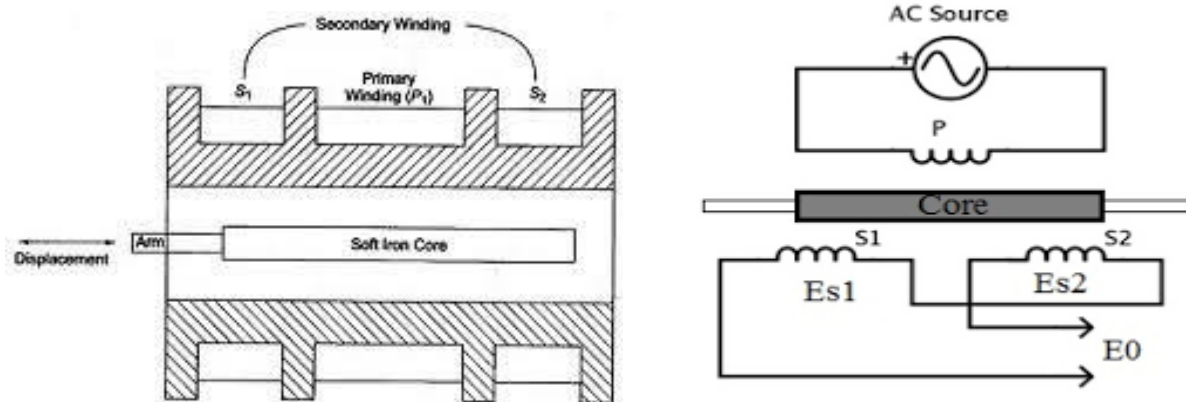

Fig. 1.1: schematic diagram of LVDT

The Output Voltage of secondary side is

$$E_o = E_{s1} - E_{s2}$$

or

$$E_o = E_{s2} - E_{s1} \text{ (depending upon the position of the core)}$$

**PROCEDURE:** - (1) Connect the power supply leads to the socket.

(2) Now adjust the null position of the L.V.D.T. and note down the residual voltage.

(3) Now move the rotating switch to make the core to move to the right side for positive readings and note down corresponding output voltages.

(4) Again repeat the above step but this time making the readings and note down the readings of output voltage.

(5) Make the observatory table

**OBSERVATION & CALCULATIONS:**

S.No.	Displacement	Output Voltage (mv)
1.		
2.		
3.		
4.		
5.		
6.		

**PRECAUTIONS:-**

1. Adjust the instrument for the null deflection.
2. Reading should be taken carefully.
3. LVDT should be handled carefully.
4. Reading from the voltmeter and displacement should be free from the observational error.

**RESULT:** - For the small change in the displacement is large change in voltage thus its sensitivity is very high. When we plot the graph between the displacement and voltages, the graph obtained should be parabolic.

**PRE EXPERIMENT QUESTIONS:**

- (1) What is the need to study about LVDT?
- (2) What are the basic parts of LVDT?

**VIVA-VOCE QUESTIONS:**

- (1) What do you understand by LVDT?
- (2) What do you understand by mutual inductance?
- (3) What is the range of displacement measured by LVDT?
- (4) Which part is moveable and fix in LVDT?
- (5) What do you understand by differential output of LVDT?

## EXPERIMENT -2

**AIM:** To study the characteristics of variable capacitor

**INTRODUCTION:** We are all familiar with batteries as a source of electrical energy. We know that when a battery is connected to a fixed load (a light bulb, for example), charge flows between its terminals. Under normal operation, the battery provides a constant current throughout its life. Furthermore, the voltage across its terminal will not vary appreciably - and when it does, it is an indication that the battery needs replacement. Capacitors are devices in which electric charges can be stored. In fact, any object in which electrons can be stripped and separated acts as a capacitor. *Capacitance* is the ability of an object to store electric charge. Practical capacitors are made of two conducting surfaces separated by an insulating layer, called a dielectric. The capacitance of an ideal capacitor is defined by  $C = Q/\Delta V$  where  $Q$  is the magnitude of the net charge on each surface, and  $\Delta V$  is the potential difference between the two conducting surfaces. The SI unit of capacitance is the **farad (F)**: 1 farad = 1 F = 1 coulomb/volt. The farad is ridiculously large. So large, in fact, that most capacitance measurements use microFarads ( $\mu\text{F}$ ), nanoFarad (nF), and picoFarads (pF) as their unit of measure. The capacitance of a capacitor filled with a dielectric is given by  $C = \kappa C_0$ , where  $C_0 = Q/\Delta V_0$  is the capacitance in the absence of the dielectric, and  $\kappa$  is the dielectric constant. The presence of a dielectric occupying the entire gap between the capacitor plates *increases* the capacitance by a factor  $\kappa$ . A list of dielectric constants of some materials (at room temperature, 1 atm) is given in following table:

Material	$K$
Vacuum	1
Air	1.00054
Paper	1.5 - 3.0
Polystyrene	2.5
Hard Rubber	2.8
Cellulose Acetate	2.9 - 4.5
Plexiglas	3.4
Nylon	3.5
Vinyl	4.0

Table 2.1: dielectric constants of some materials

There are many different types of capacitors: tubular, mica, variable, and electrolytic to name a few. A simple capacitor is the *parallel plate* capacitor, represented in Figure 2.1. The plates have an area  $A$  and are separated by a distance  $d$  with a dielectric ( $\kappa$ ) in between. The plates carry charges  $+Q$  and  $-Q$ , respectively, on their surfaces.

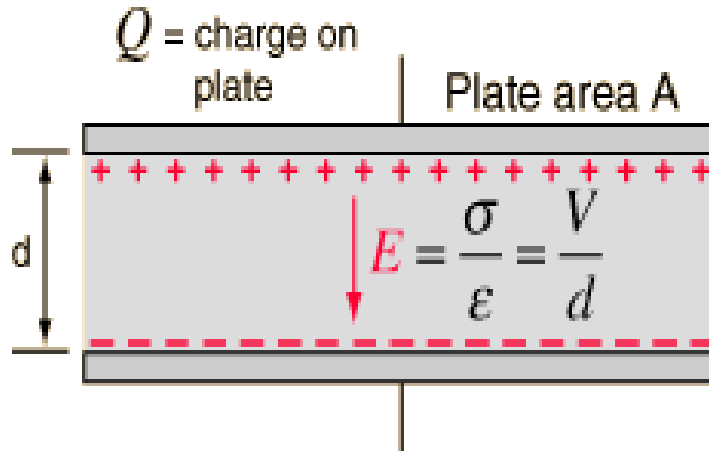

Fig. 2.1: parallel plate capacitor

The symbol used to represent capacitors in circuit schematics reflects their physical construction, common capacitors have no polarity, while electrolytic capacitors (which must be hooked up with the correct polarization) are represented by a curved plate for its negative terminal. Capacitors can be arranged in series and/or parallel. The effective net capacitances for  $n$  capacitors in series and parallel are as follows:

In this lab we will become familiar with capacitors - in series and parallel - in circuits using the breadboard. We will also use a parallel plate apparatus to investigate its capacitance with different plate spacing, and types of dielectrics.

### **CAPACITORS IN SERIES AND PARALLEL:**

This part of the lab you will be given 3 different capacitors, jumping wires, a breadboard, a multimeter and a capacitor. You will investigate how capacitors behave in series and parallel and how voltages are distributed in capacitor circuits. With the given materials, complete the following tasks:

1. Using the Capacimeter, measure the capacitance of each of the three capacitors given.
2. Connect them in series using the breadboards which have connectivity between all sets of five holes (at a minimum). Measure the effective capacitance of this combination. Repeat this for a parallel configuration. Which configuration produces a higher capacitance? Compare the measured values with those calculations.

**OBSERVATION TABLE FOR SERIES AND PARALLEL COMBINATIONS OF CAPACITORS:**

S.No.	OUTPUT in series combinations	OUTPUT in parallel combinations

**PRECAUTIONS:**

- (1) Handle the capacitors with care.
- (2) Clean the capacitors before use.

**RESULTS:** The difference can be seen in the readings for parallel and series combinations.

**VIVA-VOCE QUESTIONS:**

- (1) Explain the term dielectric.
- (2) Differentiate between the parallel and series combinations of capacitors.
- (3) The capacitance of a capacitor depends upon several components, discuss them.



## EXPERIMENT -3

**AIM:** To Study about Light Dependent Resistor (LDR).

**APPARATUS REQUIRED:** LDR kit

**THEORY:** If radiations fall on semiconductor its conductivity increases, this is called as photo-conductive effect. This effect is the basis operation of LDR. The conductivity of the material is proportional to the concentration of charge carriers present. Radiant energy supplied to the semiconductor causes covalent bonds to be broken and holes and electron pairs in excess of those generated thermally are created. This increased current circuit decreases the resistance of material and hence such a device is called as photo resistor, photo conductor of LDR. The LDR with widest application is the cadmium sulphide cell. CDS photoconductors have high dissipation capability excellent sensitivity in the visible spectrum and low resistance when stimulated by light. In this set up the LDR is used as a displacement transducer.

**CIRCUIT DESCRIPTION:** LDR is a variable resistance transducer. It is included in a potential divider circuit, which is excited by a fixed negative supply of 6.2 volts. The output voltage is available the junction of the two resistances with respect to main ground. This output voltage is coupled to the meter through a voltage follower stage. A regulated voltage of 5 volts is connected to the lamp mounted on the transducer platform. The voltage follower circuit reduces loading on the potential divider circuit effectively the arrangement tends to work as a displacement transducer.



Fig. 3.1 : LDR schematic diagram

### **PROCEDURE:**

1. Establish a connection between the lamp and the front panel socket for lamp supply.
2. Connect the .LDR to the input terminal on the front panel. Polarity is not important.
3. Connect the output terminals of transducer circuit to meter, observing polarity.
4. Adjust the channel on which LDR is mounted so that full scale deflection is obtained on the meter required, use potentiometer marked MAX on the panel.
5. Using the scale counted on the bottom of channel, measure the input displacement and he resultant meter readings.
6. Enter the readings in the table given below
7. Plot the graph of input displacement versus meter reading.

Note: the LDR is sensitive to temperature variations also.

**PRECAUTIONS:**

1. Do not expose the LDR to intense light
2. Do not connect the meter before connecting lamp and LDR to front panel.
3. Follow the computer start up procedure.

**VIVA-VOCE QUESTIONS:**

- (1) What are the applications of LDR?
- (2) What are the types of LDR?
- (3) What are the materials used for making an LDR?
- (4) The response of LDR in which form?

## Experiment -4

**AIM:** To study characteristics of strain gauge for load measurement.

**THEORY:** - If a metal conductor is stretched or length and diameter of the conductor changes. Also there are changes in the value of resistivity of conductor when strained. This property is called piezo resistive effect.

Let  $L$  = Length of wire

$D$  = Diameter of wire

$A$  = Area of cross section

In this time the gauge is utilized and the material of wire has resistivity  $\rho$ . Therefore resistance of unstrained gauge  $R = \rho L/A$ . Let us apply a tensile stress  $s$  to the wire. This produces a positive strain causing the length to increase and area to decrease, i.e. change its dimensions.

Let  $\Delta R$  = Change in resistance

$\Delta L$  = Change in length

The gauge factor is defined as the ratio of per unit change in length

$$G f = \Delta R/R$$

$\Delta L/L$  where  $E = \text{strain} = \Delta L/L$  resistance to the per unit change in length.

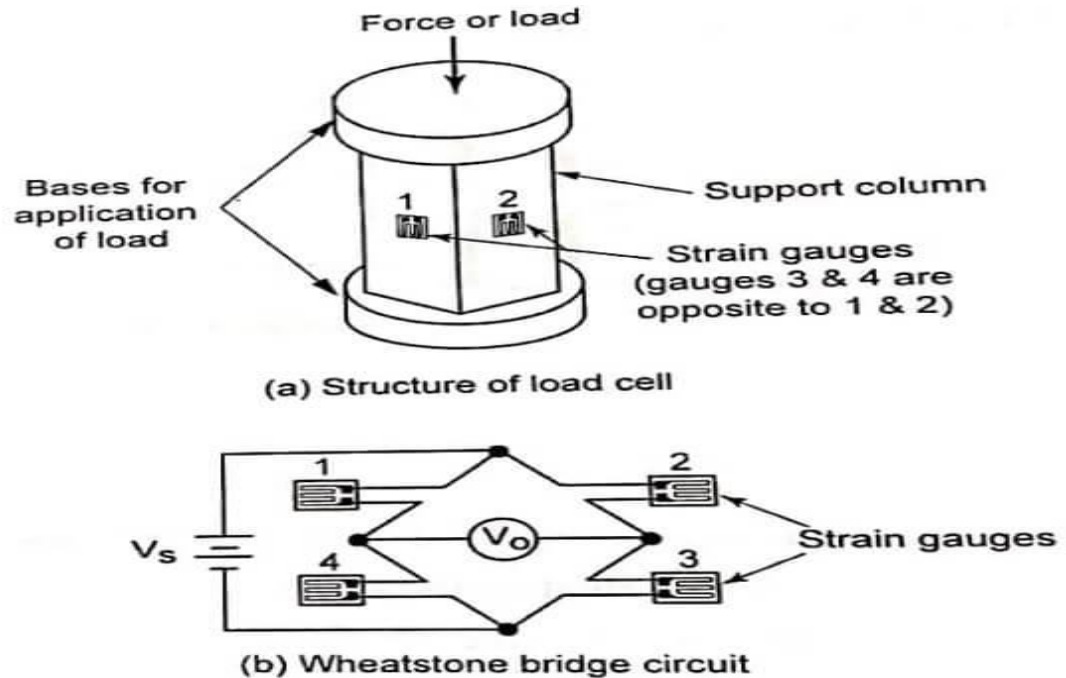

Fig 4.1: Strain Gauge diagram

**PROCEDURE:-**

1. Make the connection properly & balance the bridge.
2. Start putting weights on the cantilever beam with help of hanger & measure the  $\Delta R$  in volt on galvanometer.
3. Record the reading during loading & unloading & draw the graph.

**PRECAUTIONS:-**

1. Avoid the loading effects as far as possible.
2. Check the reading two times while loading & unloading.
3. Connections should be tight.

**RESULT:** - Strain gauges can be used for measurement of load.

**VIVA-VOCE QUESTIONS:**

- (1) What do you understand by Gauge Factor?
- (2) What is the basic principle of strain gauge?
- (3) What are the applications of strain gauge?
- (4) What do you understand by stress and strain?

## Experiment -5

**AIM:** To calibrate the D.C. crompton's Potentiometer by calibration of voltmeter method.

**APPARATUS REQUIRED:** Crompton's D.C. potentiometer circuit

**THEORY:** A practical form of D.C. potentiometer which is very widely used in crompton potentiometer. A standard westen cell is connected across terminals are standardization circuit the battery whose e.m.f. is to be measured is connected across terminals E1 & E2 with regard to polarity. The sliding contact E2 is set & the key 'K' is closed & null deflection is obtained by adjusting resistances course & fine Rheostats. The changeover switch position, if the battery whose positions is to be measured to get balanced or null deflection.

**Calibration of Voltmeter:** Voltmeter can be calibrated using DC potentiometer, any desired voltage within the range of the voltmeter to be calibrated can be obtained using the potential divider. This voltage is applied of the I/P terminal of Volt ratio box. The voltmeter to be calibrated is connected across these terminals. The output voltage of the V.R. box is measured accurately with a d.c. potentiometer.

$$\text{Theoretical value} = (\text{value voltage knob} + \text{value of mr knob}) \times (\text{m.f at V.R. box})$$

$$\text{Actual value} = \text{set value}$$

$$\% E = (AV - TV / (TV) \times 100$$

$$\text{Unknown potential} = (\text{main dial volts}) + (\text{slide wire dial volts} \times 0.001)$$

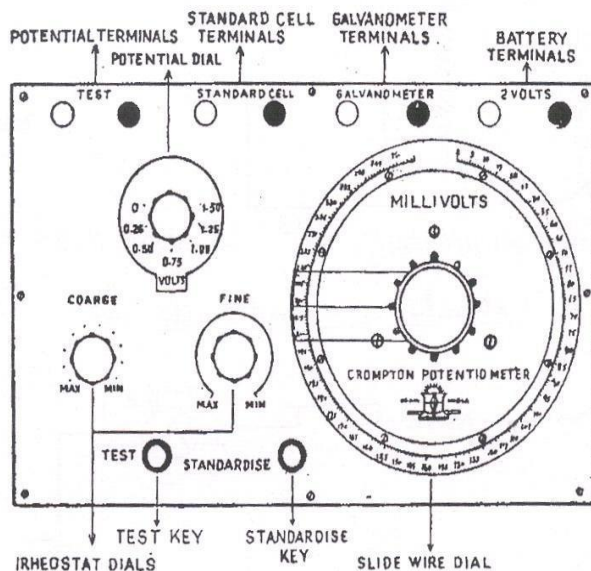

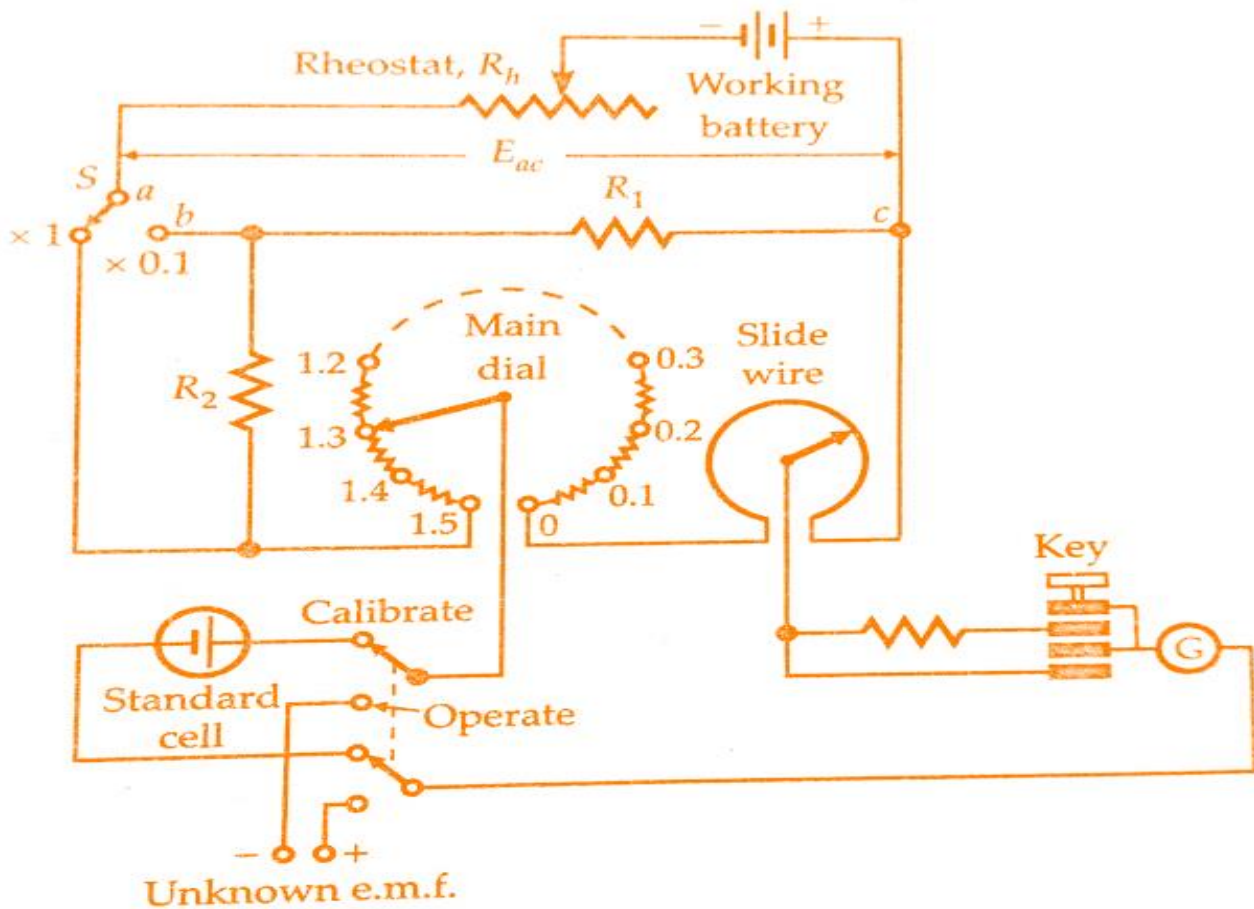

#### Calibration of Voltmeter:

1. Connect the circuit as per the circuit diagram.
  2. Keep the function key on mode either E1 to E2
  3. Set the voltage level so as to calibrate with crompton D.C. potentiometer.
  4. By adjusting voltage knob & millivolts knob for zero deflection in the galvanometer.
  5. Note down the readings by observing the p as of both knobs
  6. Calculate theoretical value by considering multiplication factor from the volratio box.
  7.  $\% \text{ Error} = \frac{(\text{Actual value} - \text{Theoretical value})}{(\text{Theoretical value})} \times 100$
- Theoretical value = (Value at voltage at knob + value at mv knob) x (m.f. at V-r knob)
- Actual value = set value.

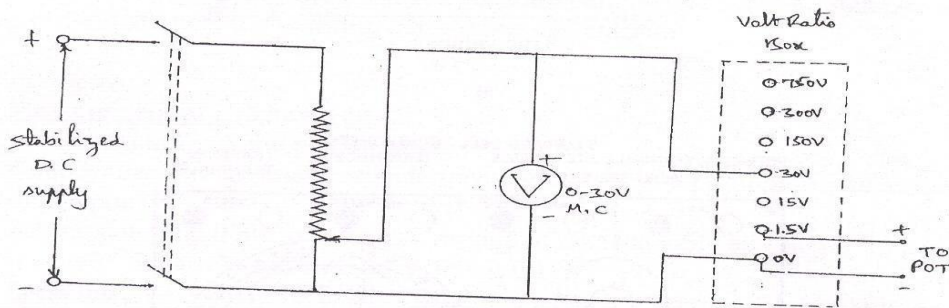

Calibration of voltmeter with pot.

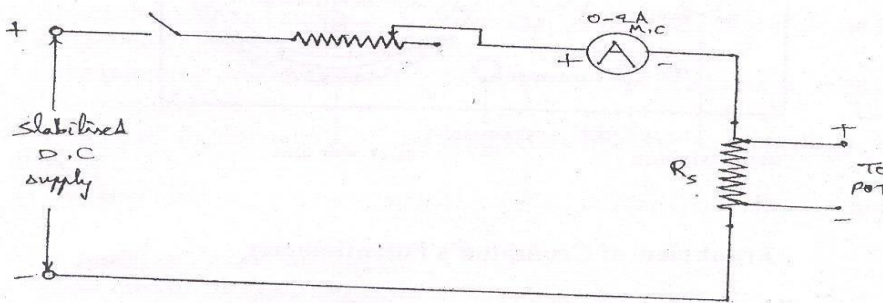

Calibration of Ammeter with pot

**OBSERVATION TABLE:**

Voltmeter reading $V_M$	True voltage measured by Pot, $V_T$	% Error = $(V_M - V_T) / V_T \times 100$

**PRECAUTIONS:**

1. D.C. potentiometer are used to calibrate voltmeter & ammeter.
2. A 2VDC supply is given to D.C. potentiometer
3. This can be achieved by standardized the giving D.C. potentiometer with the help of standard cell.
4. The connections are made as per the circuit diagram (A) placing shunt key at standard mode.
5. By adjusting course and time rheostat we observe the zero deflection

**RESULT:** Can be seen in the observation table.



## EXPERIMENT -6

**AIM:** - To study and verify the characteristics of RTD.

**APPARATUS REQUIRED:** - RTD, multimeter, power supply, hot water in pot.

**THEORY:-**The resistance of a conductor changes when its temperature is changed. This property is utilized for the measurements of temperature. Pure elements are used for the measurement of temperature. Pure elements are used for the measurement of temperature by this effect. The relationship between the resistance and change in temperature is expressed by the series

$$R_T = R_0 (1 + \alpha \Delta t + \alpha \Delta t^2 + \alpha \Delta t^3 + \alpha \Delta t^4 \dots \dots \dots \text{(n times)}).$$

Where  $\alpha$ ,  $\beta$ ---and  $\gamma$  are temperature coefficient of resistance. In the narrow range of operation  $\alpha$  and higher order coefficient are negligible so that  $R_t$  is given by:-

$$R_T = R_0 (1 + \alpha \Delta t)$$

Where  $R_T$  is the resistance of conductor at temperature  $t^\circ C$

$R_0$  is conductor having resistance at temperature  $0^\circ C$

$\alpha$  temperature coefficient of resistance.

Resistance thermometer employ a sensitive element of extremely pure platinum, copper or nickel wires that provides a definite resistance value of each temperature within the range.

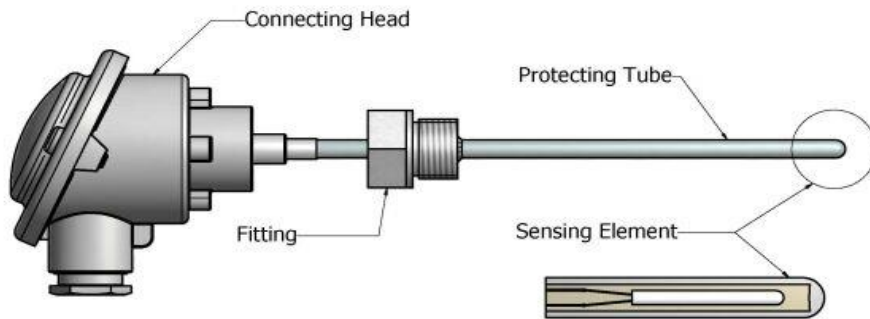

Fig. 6.1 (a): schematic diagram of RTD

**OBSERVATION TABLE:-**

S.No.	Temperature ( $^\circ C$ )	Resistance in ohm( $\Omega$ )
1.		
2.		
3.		
4.		
5.		
6.		

### **PROCEDURE:-**

1. The heater was connected to power supply after pouring water into pot.
2. The initial reading of temperature of water was taken with help of thermometer.
3. Resistance of RTD was taken with help of multi meter.
4. After the temperature of water was increased and corresponding reading of the resistance were noted and were tabulated in to table.

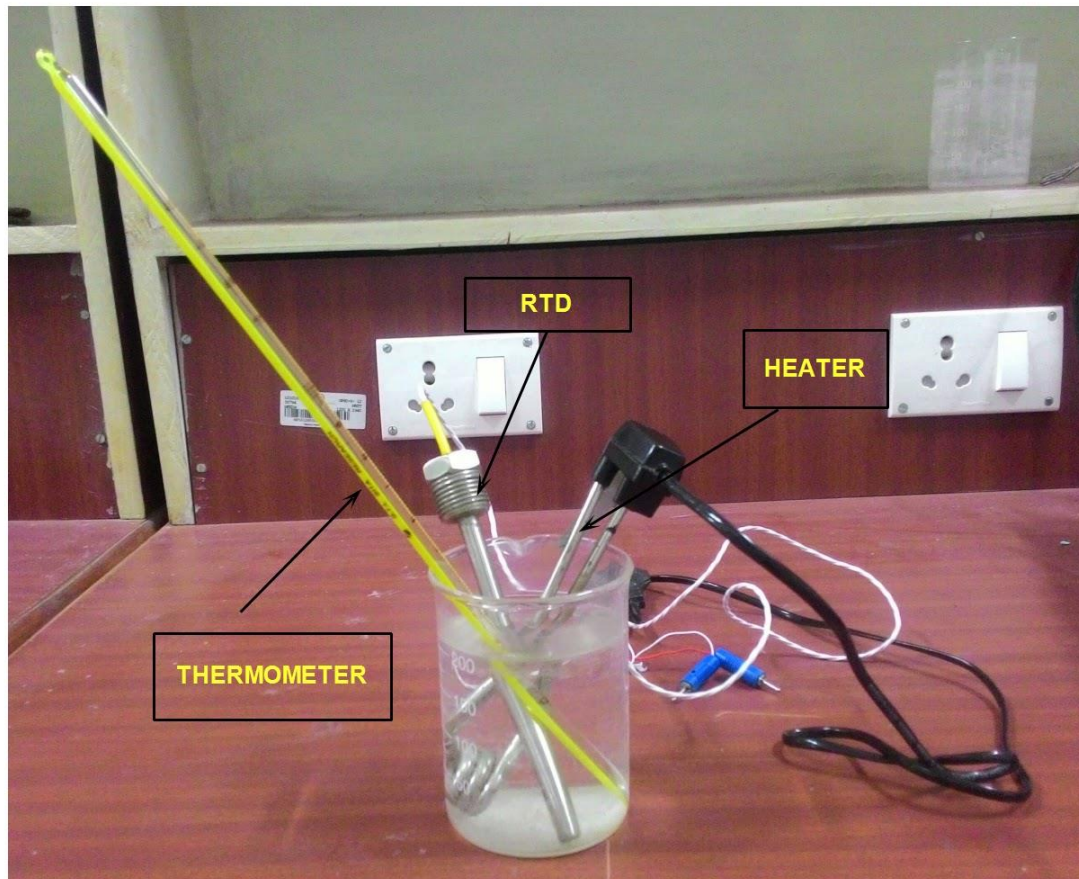
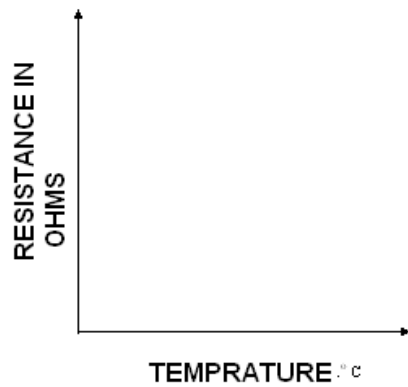

Fig. 6.1 (b): RTD Setup

### **PRECAUTIONS:-**

1. Take the reading very carefully initially as well as finally.
2. The reading should be completely immersed into water.

**RESULT:** - Observe the graph between the displacement and output voltages.



**VIVA-VOCE QUESTIONS:**

- (1) What do you understand by RTD?
- (2) What are the applications of RTD?
- (3) What do you understand by positive temperature coefficient of resistance?

## **EXPERIMENT -7**

**AIM:** To study and verify the characteristics of an n.t.c. thermistor.

**APPARATUS:** - L.G kit, multi meter, connecting leads.

**THEORY:** - The thermistor (thermally sensitive resistor) is manufacture with the intention that its value will change with temperature. Unlike a normal resistor, a large coefficient of resistance (change of resistance with temperature) is desirable. Some are made with resistance increase, which increase with temperature (+ve temperature coefficient p.t.c) or decrease (-ve temperature coefficient n.t.c). They are made in rod, disc or bead form. The construction of a typical n.t.c thermistor is shown in fig, consisting of an element made from sintered oxides if metals such as nickel, manganese and cobalt, with contacts made to each side of the element. As the temperature of the element increase, its resistance falls, the resistance temperature characteristic being non-linear. The resistance of the thermistor provided with the DIGIAC 1750 unit is of the order of  $5k\Omega$  at an ambient temperature of  $20\text{ }^{\circ}\text{C}$  ( $293\text{ }^{\circ}\text{K}$ ).

Two similar units are provided, one being mounted inside the heated enclosure. This is connected to the +5v supply and designated A. The other is mounted outside the heated enclosure. It is connected to 0v (ground) line and designed B. the circuit arrangement is shown in fig 2. The resistance of n.t.c thermistor varies over a wide range for the temperature range available within the heated enclosure if resistance reading is to be taken at regular interval of 1 minute, the reading must be obtained very quickly. The method selected connects the thermistor in series with a calibrated resistor to the +5v supply. For each reading, the variable resistor is adjusted until the voltage at the junction of the thermistor and resistor is half to the supply voltage. For this setting there will be the same voltage drop across the thermistor and the resistor and since the same current flow in each, their resistance must be equal. Hence the value of the resistance read from the calibrated resistor scale is same ass the resistance of the thermistor.

**PROCEDURE:** Connect the circuit, set the switch on the Wheatstone bridge circuit to OUT to disconnect the  $12\text{ }k\Omega$  and Rx resistor form the circuit and set the calibrated variable resistor dial reading to approximately 500.

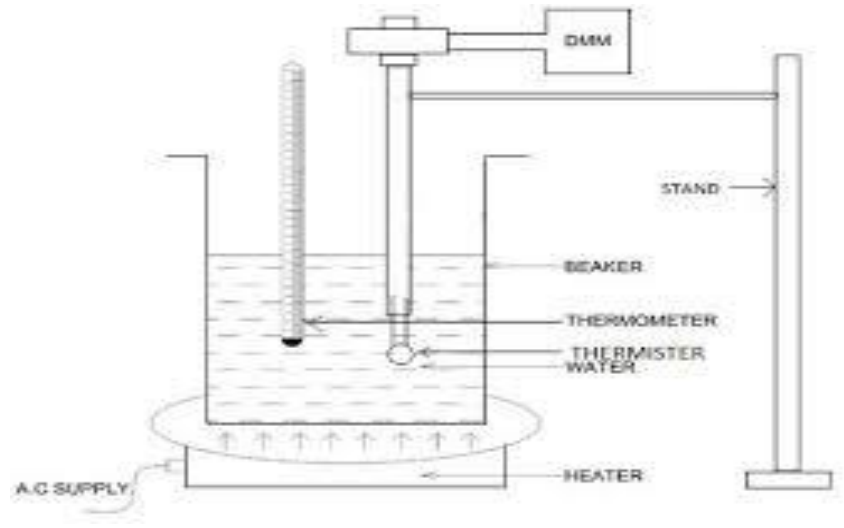

Fig. 7.1: Thermistor Setup

- Switch the power supply ON and adjust control until the value Indicated by the voltmeter is 2.5v and then note the dial reading at the temperature, by connecting the voltmeter temporarily to the INT. socket of the IC temperature sensor.

Note: since there is  $1k\Omega$  resistor in the output lead of the resistance, the total resistance will be  $10 \times \text{Dial reading} + 1k\Omega$ .

- Record the value of dial reading and temperature in table

Connect the +12v supply to the heater element input socket and at 1 minute intervals, note the value of dial reading to produce 2.5v across the resistance and also the temperature.

**Observation table: -**

Time(min.)		0	1	2	3	4	5	6	7	8	9	10
Temperature (from IC transducer)	°K											
	°C											
Dial reading for 2.5v												
Thermistor resistance ( $10 \times$ dial reading +1 $k\Omega$ )		$k\Omega$	$k\Omega$	$k\Omega$	$k\Omega$	$k\Omega$	$k\Omega$	$k\Omega$	$k\Omega$	$k\Omega$	$k\Omega$	$k\Omega$

**RESULT:** Plot the graph of thermistor resistance against temperature on the axes provided.

**VIVA-VOCE QUESTIONS:**

- (1) What are the applications of thermistor?
- (2) What do you understand by negative temperature coefficient?
- (3) What is the range of typically used thermistor?
- (4) What are the commonly used materials to construct thermistor?

## EXPERIMENT -8

**AIM:** To Study And Verify The Characteristics Of Thermocouple.

**APPARATUS REQUIRED:** - Thermocouple, multimeter, power supply, hot water in pot.

**BRIEF THEORY:** Thermocouple are perhaps the most commonly used electrical devices used for temperature measurement. The working principle of thermocouple depends on thermo-electric effect, which was, first observed by Seebeck in 1821 and is known as Seebeck effect. If two dissimilar metals are joined together so as to form a closed circuit, there will be two junctions when they meet each other. If one of these junctions is heated, current flows in the circuit, which can be detected by a galvanometer. The magnitude of current so produced depends on the temperature difference between two junctions and characteristics of two metals.

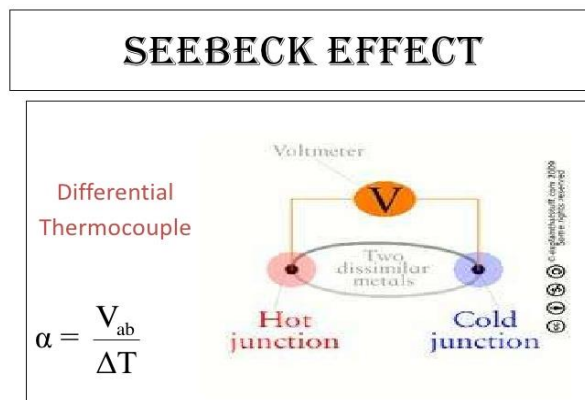

Fig 8.1: principle of a thermocouple

There is a list of pair of metals, which can be used as a thermocouple. Few of them are listed in the table:

Materials	Temperature range (Degree Celsius)	Emf at 500 (MV)
Copper/Constantan	-200 to 400	27.6
Iron/Constantan	0 to 900	26.7
Chromel/Alumel	-18 to 276	23.0
Nickel/Nickel	0 to 1100	10.0
Platinum/Platinum-Rhodium	500 to 1400	4.5

A practical thermocouple circuit having two dissimilar metals X and Y are joined together to form junction J1. The other junction is opened and a mill-voltmeter is connected to form junction J2 and J3. Thus, two new differentially arranged thermocouples have been formed with their temperatures being equal to T2. If T2 is kept constant at 0 degree, the temperature difference T between T1 and T2 could be same as T1. In case T2 is kept constant at some other temperature, say 15 degree then

$$T = T1 - 15$$

Though the connecting leads made of material z make junction J2 with X and J3 with J their thermo-emf is cancelled because both the junctions J2 and J3 are at the same temperature.

**PROCEDURE:**

1. Arrange the equipment as according to the requirement.
2. Record the initial temperature and Emf of thermocouple. An electronic or digital multimeter may be used for measurement of output voltage.
3. Switch on the heating device. Observe and record temperature and corresponding emf of thermocouple.
4. Plot a graph between temperature and Emf of thermocouple.

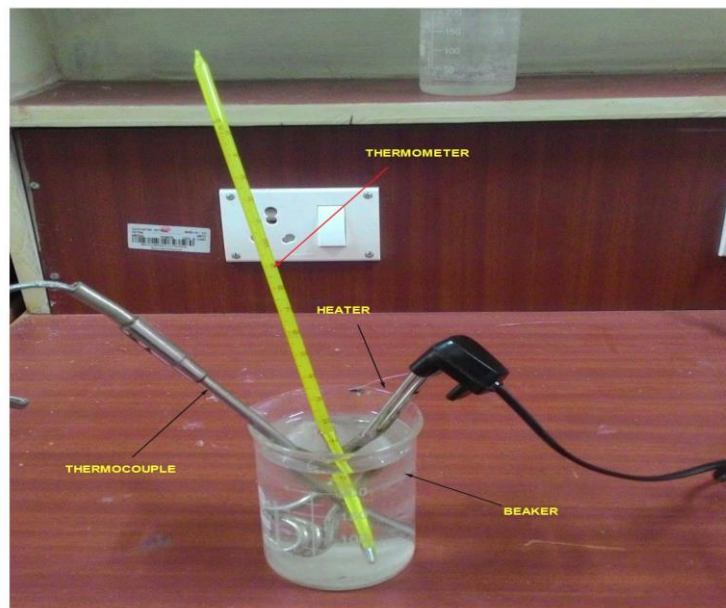

Fig. 8.2: Thermocouple Setup

**OBSEVATION TABLE:**

Sr. No.	Temperature (degree Celsius)	Emf(mv)

**RESULTS:** Variations can be seen in the observation table and a temperature Vs EMF graph can be plotted.



**VIVA-VOCE QUESTIONS:**

- (1) What are the basic principles behind the thermocouples?
- (2) What are the different materials used for the construction of a thermocouple?
- (3) What is the difference between the thermocouple and thermistor?
- (4) What are the applications of thermocouple? Express some industrial applications of it.